

TOWN OF SEABROOK ISLAND

Planning Commission Regular Meeting

March 9, 2022 – 1:30PM

Town Hall, Council Chambers
2001 Seabrook Island Road
Seabrook Island, SC 29455



[Watch Live Stream \(YouTube\)](#)

Participate in the Meeting: Individuals who wish to participate in the meeting via Zoom may access the meeting as follows:

- [Instructions for Joining & Participating in the Virtual Meeting](#)
- **To join by computer, tablet or mobile device:**
<https://us02web.zoom.us/j/82271205144?pwd=bGNPMnRaSmFWKzBUVkl2N3hVl3hLUT09>
- **To join by phone:** Call (646) 558-8656 **Please note that long distance rates may apply**
- **Meeting ID:** 822 7120 5144 **Passcode:** 332400

AGENDA

CALL TO ORDER

APPROVAL OF MINUTES

1. **Regular Meeting: February 9, 2022** *[pages 3 – 5]*

OLD BUSINESS ITEMS

There are no old business items

NEW BUSINESS ITEMS

1. **Commercial Site Plan Review: The Club at Seabrook Island Storage Area & Fence Enclosure**

Request from John Fitzpatrick, on behalf of The Seabrook Island Club, to construct a storage area as well as a 6' tall fence enclosure. *[pages 6 – 20]*

2. **Commercial Site Plan Review: The Club at Seabrook Island Deck Addition**

Request from John Fitzpatrick, on behalf of The Seabrook Island Club, to increase the size of an existing deck located at the Seabrook Island Club. *[pages 21 – 29]*

3. **Commercial Site Plan Review: Bohicket Marina Day Docks**

Request from Bohicket Creek Investors, LLC to install three sections of floating docks at Bohicket Marina. *[pages 30 – 43]*

ITEMS FOR INFORMATION / DISCUSSION

There are no items for information/discussion

ADJOURN

TOWN OF SEABROOK ISLAND

Planning Commission

February 9, 2022

Virtual Meeting (Zoom)

[Watch Live Stream \(YouTube\)](#)



MINUTES

Present: Ken Ostort (Chair), Stan Ullner (Vice Chair), Wayne Billian, Jim Newton, Sharon Welch, Joe Cronin (Town Administrator), Tyler Newman (Zoning Administrator)

Absent: None.

Guests: Paul LeBlanc (Consultant from PLB Planning Group)

Acting Chairman Ostort called the meeting to order at 1:30PM and welcomed everyone in attendance. Town Administrator Cronin confirmed that the requirements of the Freedom of Information Act were fulfilled, and the meeting agenda was properly posted.

APPROVAL OF MINUTES

1. Special Called Meeting: January 6th, 2022

Mr. Newton moved to approve the previous meeting minutes of January 6th, 2022; Mr. Ullner seconded. All voted in favor.

The previous meeting minutes of January 6th, 2022 were approved.

ELECTION OF OFFICERS

1. Election of Chair for 2022

Mr. Ostort moved to nominate Sharon Welch; Ms. Welch seconded.

Mr. Newton moved to nominate Stan Ullner; Mr. Billian seconded.

Town Administrator Cronin advised as two members were nominated for the position, each Commissioner shall have one vote, and state the name of the candidate they would like to appoint as Chair. The votes were taken as follows:

Ullner:	Billian, Newton, Ullner
Welch:	None.
Abstain:	Ostort
No Vote:	Welch

Stan Ullner was appointed of the Chair of the Planning Commission.

2. Election of Vice Chair for 2022

Mr. Newton moved to nominate Wayne Billian as Vice Chair; Mr. Billiam seconded. All voted in favor.

Wayne Billian was appointed as Vice Chair.

OLD BUSINESS ITEMS

Mr. Ostort updated the commission on the Camp St. Christopher temporary use request for the temporary kitchen trailer along with the refrigeration unit.

Mr. Ostort added that the temporary use permit was only valid for 60 days and discussed the process for requesting an extension process for the temporary use permit. Town Administrator Cronin and Zoning Administrator Newman clarified that each extension needed would need to be requested every 60 days since it is a temporary structure.

NEW BUSINESS ITEMS

1. Draft Development Standards Ordinance (DSO)

Planning Commissioners discussed the proposed zoning of Jenkins Point and potentially bringing this draft back to the advisory committee.

Town Administrator Cronin and Mr. LeBlanc clarified the zoning designation of Jenkins Point and what an Agricultural District allows vs. Residential District.

Mr. Billian moved to approve the draft DSO for recommendation to Town Council; Mr. Ostort seconded. A vote was taken as follows:

Ayes:	Billian, Ostort, Welch, Chairman Ullner
Abstain:	Newton

The draft DSO was approved for recommendation to Town Council.

Mr. Billian left the meeting after the vote was taken.

2. Draft Zoning Map

Planning Commissioners discussed the proposed draft zoning map.

Mr. Ostort moved to approve the draft zoning map for recommendation to Town Council; Ms. Welch seconded. All voted in favor.

The draft Zoning Map was approved for recommendation to Town Council.

ITEMS FOR INFORMATION / DISCUSSION

None.

ADJOURN

Mr. Ostort moved to adjourn the meeting; Mr. Newton seconded. All voted in favor.

The meeting adjourned at 3:27PM.

Date: February 18, 2022

Prepared by: *Katharine E. Watkins*
Town Clerk/Treasurer



MEMORANDUM

TO: Planning Commission Members

FROM: Tyler Newman, Zoning Administrator

SUBJECT: Commercial Plan Review: Seabrook Island Club Storage Area & Fence Enclosure

MEETING DATE: March 9, 2022

The Planning Commission is asked to review and approve a request from John Fitzpatrick, on behalf of the Seabrook Island Club, to construct a storage area as well as a 6’ tall fence enclosure. The storage area and fence enclosure will both be located at the Beach Club Pools property which is addressed both 3768 and 3772 Seabrook Island Road with a Charleston County Tax Map Number of 147-05-00-085.

The proposed storage area will consist of enclosing an existing concrete pad that is adjacent to an existing building on site. The storage area will be 6.5’ x 8’ (52 square feet), framed with pressure treated framing (2 x 6), IPE scrim siding that matches the current building (1 x 4), barn door hardware and door matching the existing door, and a metal roof matching the current roof structure (see photos).

The proposed fence is intended to screen an existing cardboard recycling container on site. The fence will be 6’ tall, three sided, and have dimensions of 9’ x 15’ (135 square feet). The fence will be constructed out of wood that matches the existing fence near the pool area and will be the same color as the gates on the on the trash compactor also located on site (see photos).

The property is zoned PDD – Commercial-Retail/Office (CRO) and is properly zoned for a club house and associated facilities/structures.

Copies of the applicant’s narrative, site plans, floor plan, and site photos are included for review.

Staff Recommendation

The proposed storage area and fence were reviewed by town staff and found to comply with all requirements of the Development Standards Ordinance. Therefore, staff recommends in favor of **APPROVAL** of the request, subject to the Planning Commission’s review and approval of proposed materials and colors.

While Article 14 of the Development Standards Ordinance requires Planning Commission review of both a Preliminary and Final Site Plan, given the limited scope of this project, as well as its conforming status, staff recommends approving the drawing as submitted and waiving the requirement for an additional Final Site Plan Review.

Respectfully submitted,

Tyler Newman
Zoning Administrator

TOWN OF SEABROOK ISLAND

**2001 Seabrook Island Road
Seabrook Island, SC 29455
843-768-9121**

ZONING PERMIT APPLICATION

New Construction:	\$200.00 (SF) / \$350.00 (MF/Commercial)		
Addition:	\$150.00 (SF) / \$250.00 (MF/Commercial)		
Major Renovation (>50% FMV):	\$200.00 (SF) / \$250.00-\$350.00 (MF/Commercial)		
Minor Renovation (≤50% FMV):	\$25.00 (SF) / \$25.00-\$150.00 (MF/Commercial)		
Minor Repairs & Maintenance:	No Charge	Change of Use:	\$50.00
Accessory Use/Structure:	\$50.00	Home Occupation:	\$25.00

Date: 2/10/2022 **TMS #:** 1470500085

Applicant's Name: The Club at Seabrook

Name of Business Contact: John Fitzpatrick

Address: 2890 Seabrook Island Rd **Phone:** 620-762-3489

City: Seabrook Island **State:** SC **Zip:** 29455

Property Owner's Name: The Club at Seabrook Island

Address: 1002 Landfall Way **Phone:** 843-768-2500

City: Seabrook Island **State:** SC **Zip:** 29455

Property Location Address: 3772 Seabrook Island Rd

Lot: _____ **Block:** _____ **Base Flood Elev.** 12' **Zone:** Commercial

Purpose of Permit: Box area for storage \$34,000
Fence around recycling \$750

Value of Construction: _____ **POA Approval:** _____

Applicant's Signature: _____

****This is an application only. The permit will be issued upon approval by the Town of Seabrook Island.**



SEABROOK ISLAND
CLUB

To the Town of Seabrook Island Planning Commission.

After using our new bar for two years we have found that we need a better storage area that can be secured. We would like to enclose an area next to our current building for storage purposes. It will be on the current concrete pad, framed with 2 x 6 pressure treated framing and 1 x 4 IPE scrim siding that matches the current building. With barn door hardware and door matching current door.

We will also put a metal roof matching the current roof structure. All work will be code compliant with Charleston County building code.

Current value of Building \$765,000 and the new work will be \$34,000.

We have a cardboard recycling container outside of the kitchen of the Pelicans nest sitting on a concrete slab. We would like to fence 3 sides of this slab with a wooden fence structure that matches the fence by the pool area. This would be 2 sections 9' wide and one section 15' long. The height of the fence would be 6' tall. It will be the same color as the gates on the trash compactor that is a few feet away.

John Fitzpatrick

Overall Site Plan

TOWN OF SEABROOK DEVELOPMENT STANDARDS

Sec. 9.30. - Oceanfront and North Edisto River Property Setbacks.

9.30.20. Minimum Setbacks. For all oceanfront and North Edisto River property, the minimum required setback from the ocean for any structure shall be the greater (most landward) of:

9.30.21. The setback line mandated by the SC Coastal Tidelands and Wetlands Act of 1977 (State Code Sections 48-39-10 et seq.), as amended in 1988 and thereafter; and

9.30.22. A line drawn parallel to the front (street side) property line and extending from the front property line the distance equal to seventy-five (75%) percent of the platted, average lot depth as measured from the front property line; and

9.30.23. In no event shall construction be closer than (seaward of) thirty (30) feet landward from the landward edge of the primary dune or the dune formed by any existing revetment.

The project is in compliance of front and rear setback lines; see plan setback lines in red. - - - -

Sec. 10.60. - Specifications for Walls, Fences and Hedges.

Walls and Fences. In the event a wall or fence is used or required, the following requirements shall apply:

(L) The requirements of this section shall not apply to the repair, replacement or reconstruction of any wall or fence which was legally in existence as of the effective date of this ordinance. Any such wall or fence may be repaired, replaced or reconstructed, provided: a. The extent of any non-conforming element shall not be increased. For the purpose of this section, the term "element" shall include the design, materials, height and/or location of the existing fence;

The front entry fence is a replacement of the existing fence and does not change in horizontal or vertical layout.

THIS DRAWING SHALL NOT BE REPRODUCED IN ANY MANNER OR USED FOR ANY PURPOSE WITHOUT WRITTEN PERMISSION.

601 HANCOCK PARK BOULEVARD, SUITE 200 | MOUNT PLEASANT, SC 29566 | 803-887-2222 | SEAMON WHITESIDE & ASSOCIATES, INC.

COPYRIGHT © SEAMON WHITESIDE & ASSOCIATES, INC.

PROJECT: 2019-03-04 | 2019-03-04 | 2019-03-04 | 2019-03-04

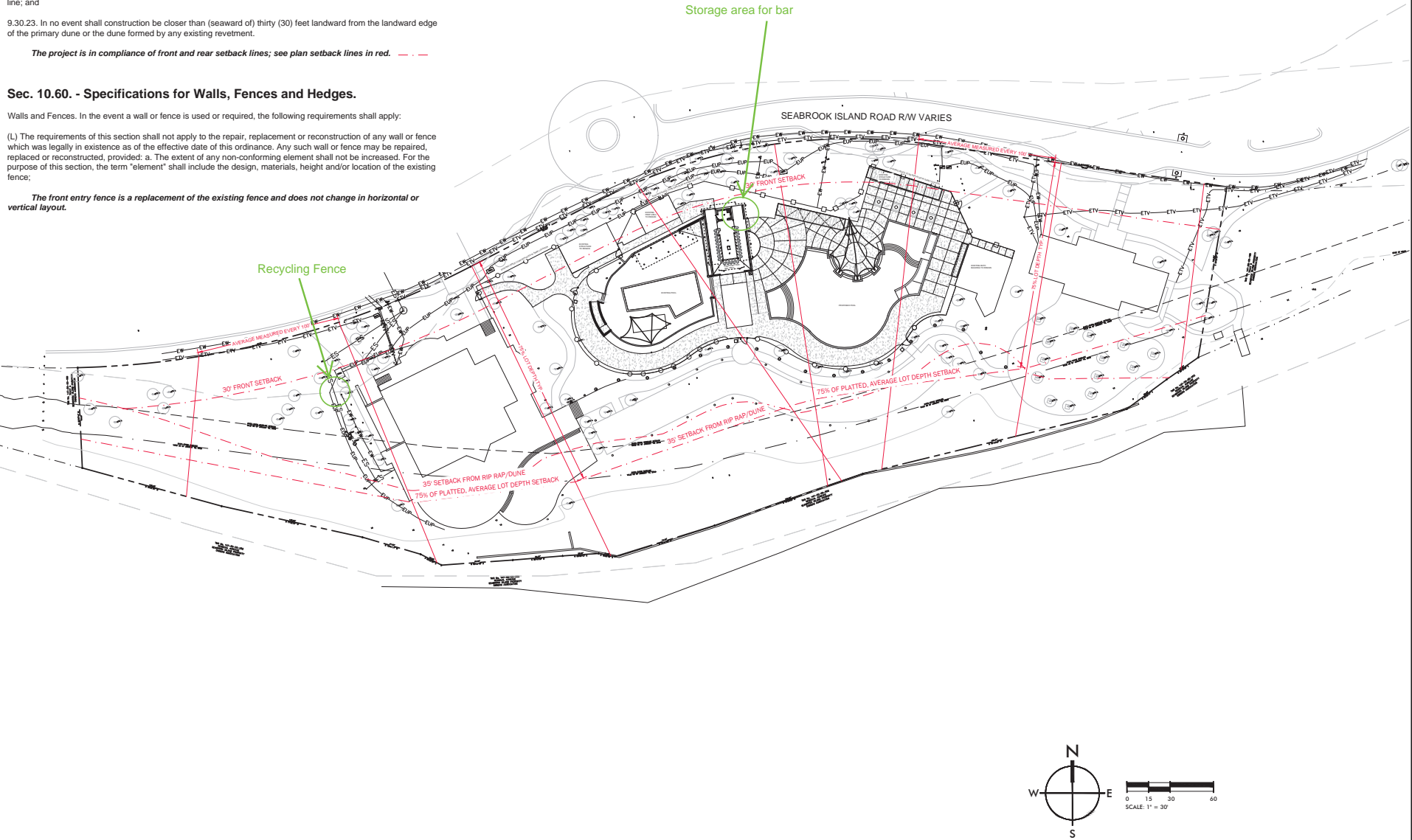

MOUNT PLEASANT, SC 843.884.1967
 GREENVILLE, SC 864.298.0534
 SUMMERVILLE, SC 843.884.1967
 SPARTANBURG, SC 864.298.0534
 CHARLOTTE, NC 980.312.5450
 WWW.SEAMONWHITESIDE.COM



**SEABROOK BEACH CLUB
 POOL RENOVATION**
 SEABROOK ISLAND, SOUTH CAROLINA

VE REVISIONS/ IFC SET

SW+ PROJECT:	7993
DATE:	8/28/2019
DRAWN BY:	WJK
CHECKED BY:	MM

REVISION HISTORY

ZONING - SETBACKS

L-0.0

Site Plan: Blue highlighted area shows proposed 6.5' x 8' storage area

TOWN OF SEABROOK DEVELOPMENT STANDARDS

Sec. 9.30. - Oceanfront and North Edisto River Property Setbacks.

9.30.20. Minimum Setbacks. For all oceanfront and North Edisto River property, the minimum required setback from the ocean for any structure shall be the greater (most landward) of:

9.30.21. The setback line mandated by the SC Coastal Tidelands and Wetlands Act of 1977 (State Code Sections 48-39-10 et seq.), as amended in 1988 and thereafter; and

9.30.22. A line drawn parallel to the front (street side) property line and extending from the front property line the distance equal to seventy-five (75%) percent of the platted, average lot depth as measured from the front property line; and

9.30.23. In no event shall construction be closer than (seaward of) thirty (30) feet landward from the landward edge of the primary dune or the dune formed by any existing revetment.

The project is in compliance of front and rear setback lines; see plan setback lines in red. - - -

Sec. 10.60. - Specifications for Walls, Fences and Hedges.

Walls and Fences. In the event a wall or fence is used or required, the following requirements shall apply:

(L) The requirements of this section shall not apply to the repair, replacement or reconstruction of any wall or fence which was legally in existence as of the effective date of this ordinance. Any such wall or fence may be repaired, replaced or reconstructed, provided: a. The extent of any non-conforming element shall not be increased. For the purpose of this section, the term "element" shall include the design, materials, height and/or location of the existing fence;

The front entry fence is a replacement of the existing fence and does not change in horizontal or vertical layout.

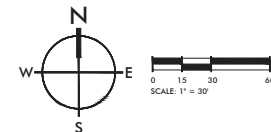
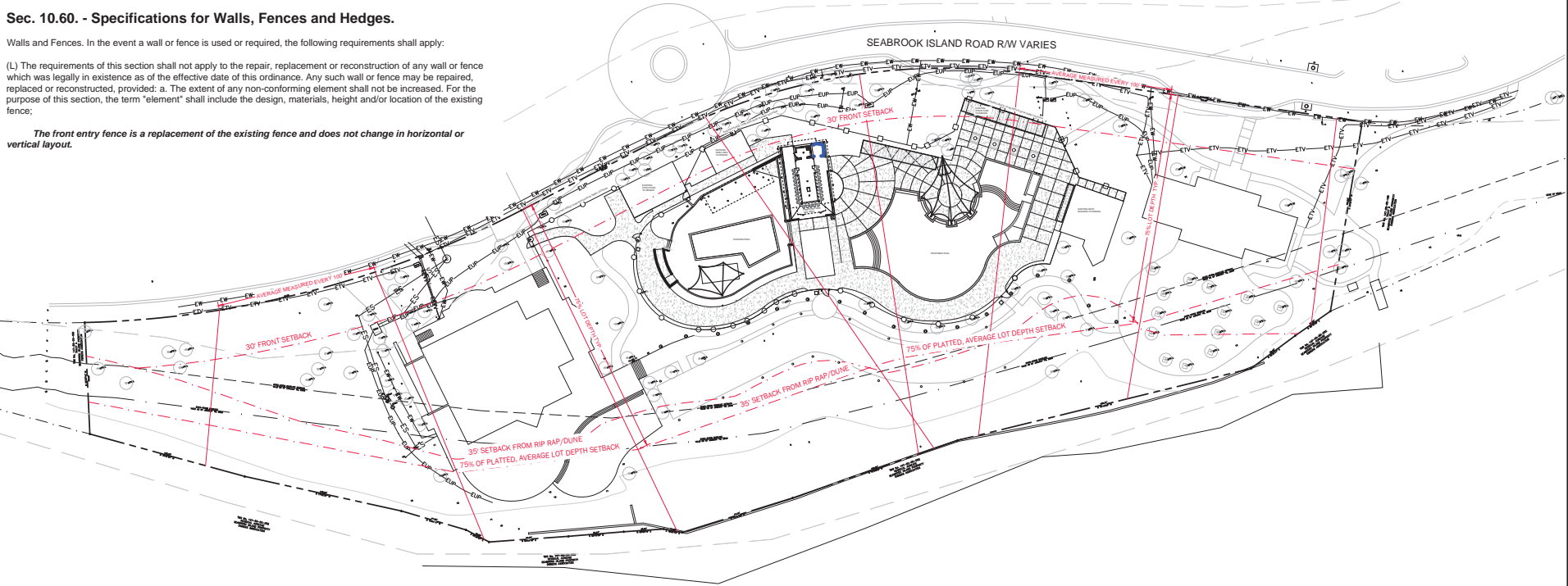

MOUNT PLEASANT, SC 843.884.1967
 GREENVILLE, SC 864.298.0534
 SUMMERVILLE, SC 843.884.1967
 SPARTANBURG, SC 864.298.0534
 CHARLOTTE, NC 980.312.5450
 WWW.SEAMONWHITESIDE.COM



**SEABROOK BEACH CLUB
 POOL RENOVATION**
 SEABROOK ISLAND, SOUTH CAROLINA

VE REVISIONS/ IFC SET

SW+ PROJECT:	7993
DATE:	8/28/2019
DRAWN BY:	WJK
CHECKED BY:	MM

REVISION HISTORY

ZONING - SETBACKS

L-0.0

THIS DRAWING SHALL NOT BE REPRODUCED IN ANY MANNER OR USED FOR ANY PURPOSE WITHOUT WRITTEN PERMISSION.
 601 HANCOCK PARK BOULEVARD, SUITE 200, MOUNT PLEASANT, SC 29566 | 803.867.2222 | 803.867.2222
 COPYRIGHT © SEAMON WHITESIDE & ASSOCIATES, INC.

Site Plan: Blue arrow indicates location of proposed 9' x 15' fence (6' height)

TOWN OF SEABROOK DEVELOPMENT STANDARDS

Sec. 9.30. - Oceanfront and North Edisto River Property Setbacks.

9.30.20. Minimum Setbacks. For all oceanfront and North Edisto River property, the minimum required setback from the ocean for any structure shall be the greater (most landward) of:

9.30.21. The setback line mandated by the SC Coastal Tidelands and Wetlands Act of 1977 (State Code Sections 48-39-10 et seq.), as amended in 1988 and thereafter; and

9.30.22. A line drawn parallel to the front (street side) property line and extending from the front property line the distance equal to seventy-five (75%) percent of the platted, average lot depth as measured from the front property line; and

9.30.23. In no event shall construction be closer than (seaward of) thirty (30) feet landward from the landward edge of the primary dune or the dune formed by any existing revetment.

The project is in compliance of front and rear setback lines; see plan setback lines in red.

Sec. 10.60. - Specifications for Walls, Fences and Hedges.

Walls and Fences. In the event a wall or fence is used or required, the following requirements shall apply:

(L) The requirements of this section shall not apply to the repair, replacement or reconstruction of any wall or fence which was legally in existence as of the effective date of this ordinance. Any such wall or fence may be repaired, replaced or reconstructed, provided: a. The extent of any non-conforming element shall not be increased. For the purpose of this section, the term "element" shall include the design, materials, height and/or location of the existing fence;

The front entry fence is a replacement of the existing fence and does not change in horizontal or vertical layout.

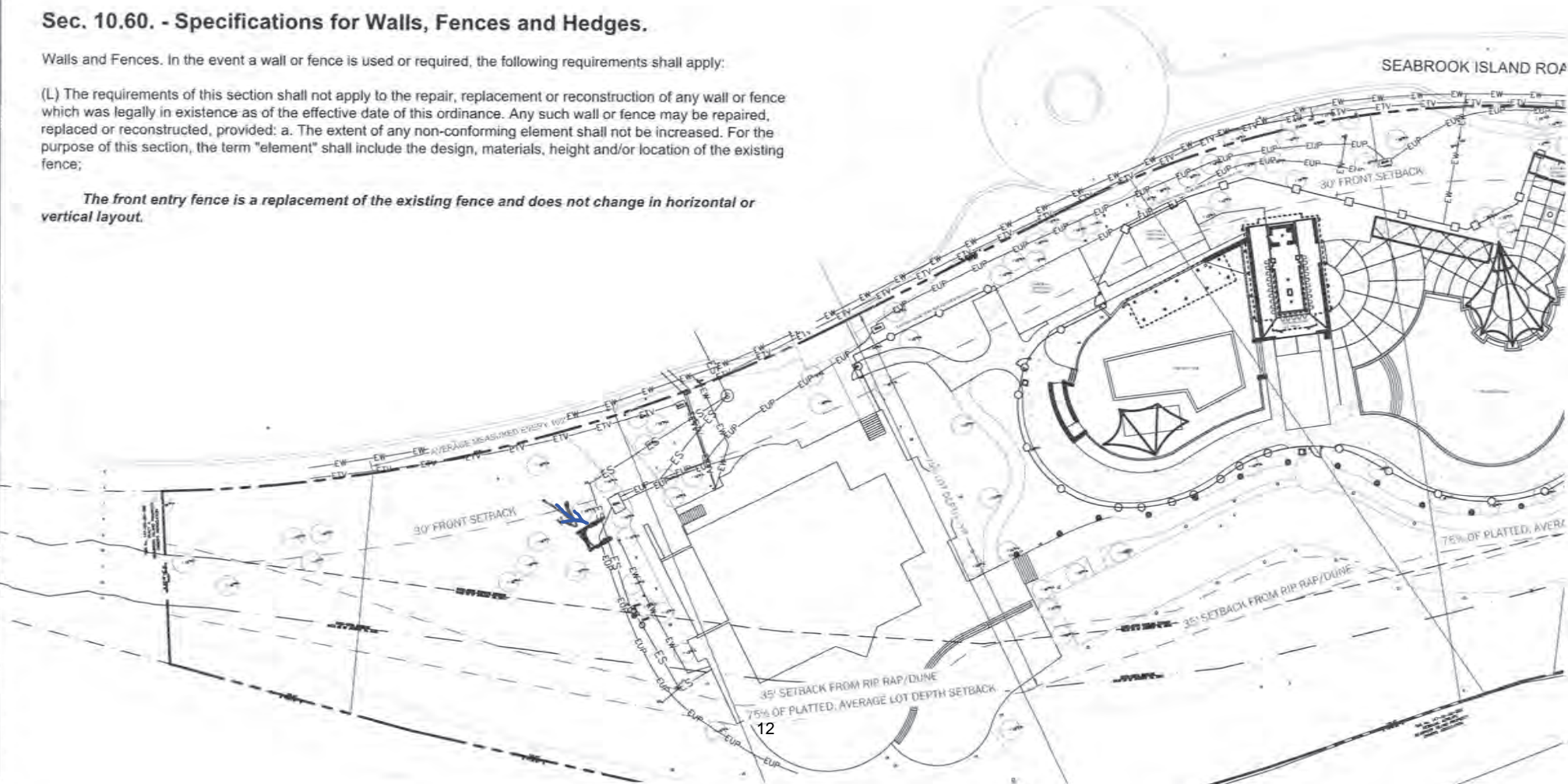

THIS DRAWING SHALL NOT BE REPRODUCED IN ANY MANNER OR USED FOR ANY PURPOSE WITHOUT WRITTEN PERMISSION. SUITE 200 | MOUNT PLEASANT, SC 29464 | 508 RHETT STREET, SUITE 101 | GREENVILLE, SC 29601

Zoomed in view of proposed recycling fence location

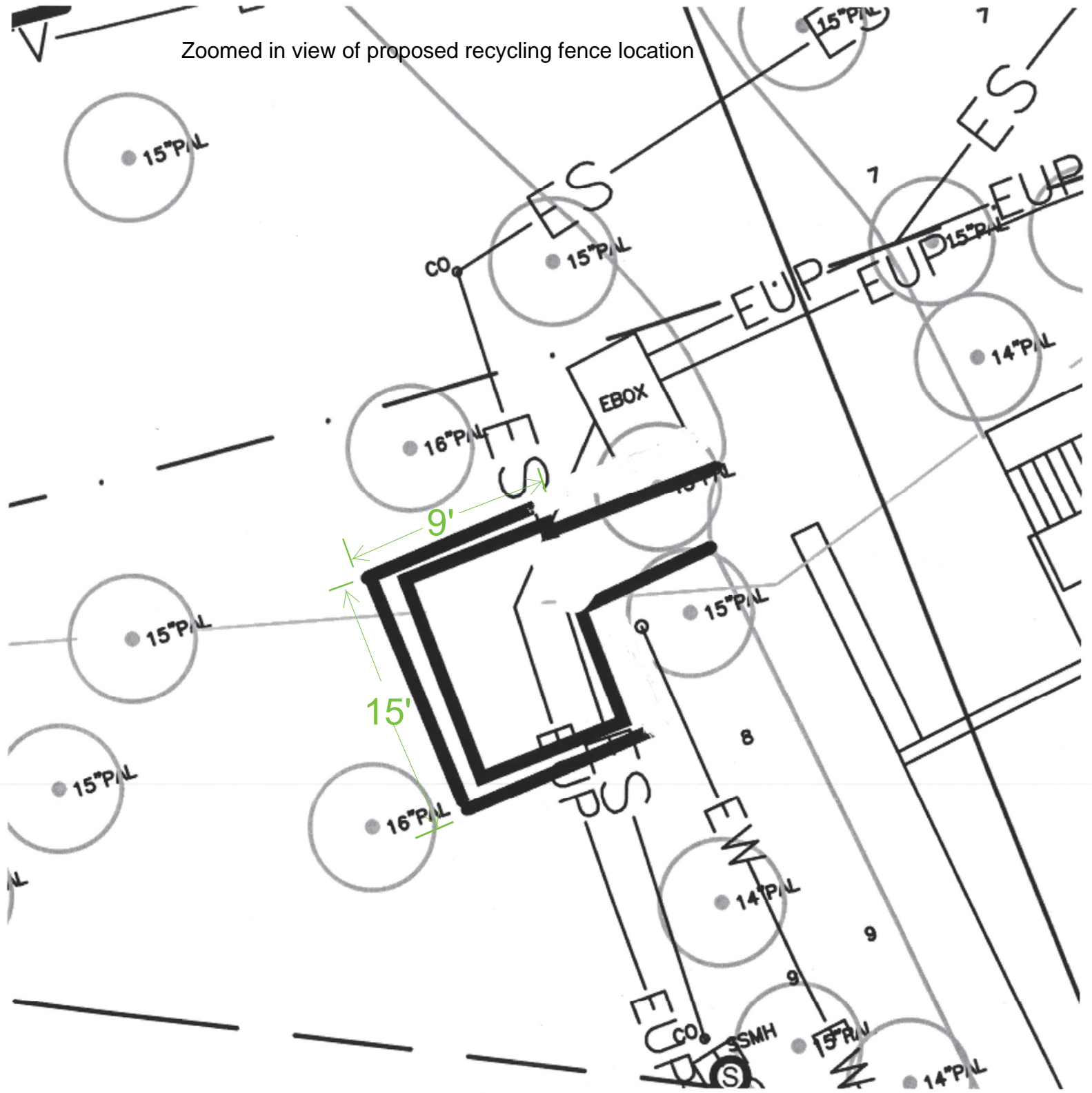



Proposed Storage Area Location



Proposed Storage Area Location



Existing Recycling Area





Existing Fence



THE GUERRY GROUP

REAL ESTATE ANALYSTS, CONSULTANTS AND APPRAISERS

Cost Analysis - Section 2 of 3

Marshall & Swift, Contractor Surveys

Ocean Terrace

Item	Unit Type	Cost	Multiplier	Adjusted Cost	Quantity	Total
Ocean Terrace	Sq. Ft.	\$175.00	1.000	\$175.00	2,839	\$496,825
Total Building Improvement Costs						\$496,825
Rounded to the nearest \$5,000						\$495,000
Price per SF Gross Building Area						\$175.00

Cost Analysis - Section 3 of 3

Marshall & Swift, Contractor Surveys

Beach Club Pool Facility

Item	Unit Type	Cost	Multiplier	Adjusted Cost	Quantity	Total (Rounded)
Beach Club Towel Building	Sq. Ft.	\$150.00	1.000	\$150.00	738	\$110,000
Beach Club Bath House	Sq. Ft.	\$150.00	1.000	\$150.00	1,116	\$165,000
Cap'n Sam's Grill	Sq. Ft.	\$600.00	1.000	\$600.00	1,278	\$765,000
Pools	Sq. Ft.	\$150.00	1.000	\$150.00	6,000	\$900,000
Pool Patio	Sq. Ft.	\$12.00	1.000	\$12.00	22,000	\$265,000
Ocean Terrace Patio	Sq. Ft.	\$15.00	1.000	\$15.00	6,112	\$90,000
Pool Shade Shelters, Gazebos, Fencing, Etc	Lump Sum	\$500,000.00	1.000	\$500,000.00	1	\$500,000
Total Cost						\$2,795,000
Rounded to the nearest \$5,000						\$2,795,000
Cost Per Square Foot Gross Building Area						\$3,787.26



MEMORANDUM

TO: Planning Commission Members
FROM: Tyler Newman, Zoning Administrator
SUBJECT: Commercial Plan Review: Seabrook Island Club Deck Addition
MEETING DATE: March 9, 2022

The Planning Commission is asked to review and approve a request from John Fitzpatrick, on behalf of The Seabrook Island Club, to expand an existing deck located at the rear of the club house building. The deck expansion project will be located at the at the Seabrook Island Club club house property which is addressed 3771 Seabrook Island Road with a Charleston County Tax Map Number of 147-05-00-018.

Per the applicant’s narrative the existing deck is frequently used by club members and has become a very busy congregating spot therefore they would like to increase the size of the deck to allow for a larger congregation area. The proposed deck expansion will consist of adding 300 square feet (SF) of wood deck to the already existing 680 SF wood deck located at the rear of the club house building. All material associated with the new 300 SF of deck will match the existing deck on site.

The property is zoned PDD – Commercial-Retail/Office (CRO) and is properly zoned for a club house and associated facilities/structures.

Copies of the applicant’s narrative, site plan, architectural plans, and photos of the existing deck are included for review.

Staff Recommendation

The proposed deck expansion was reviewed by town staff and found to comply with all requirements of the Development Standards Ordinance. Therefore, staff recommends in favor of **APPROVAL** of the request, subject to the Planning Commission’s review and approval of proposed materials and colors.

While Article 14 of the Development Standards Ordinance requires Planning Commission review of both a Preliminary and Final Site Plan, given the limited scope of this project, as well as its conforming status, staff recommends approving the drawing as submitted and waiving the requirement for an additional Final Site Plan Review.

Respectfully submitted,

Tyler Newman
 Zoning Administrator

TOWN OF SEABROOK ISLAND
2001 Seabrook Island Road
Seabrook Island, SC 29455
843-768-9121

ZONING PERMIT APPLICATION

New Construction:	\$200.00 (SF) / \$350.00 (MF/Commercial)	
Addition:	\$150.00 (SF) / \$250.00 (MF/Commercial)	
Major Renovation (>50% FMV):	\$200.00 (SF) / \$250.00-\$350.00 (MF/Commercial)	
Minor Renovation (≤50% FMV):	\$25.00 (SF) / \$25.00-\$150.00 (MF/Commercial)	
Minor Repairs & Maintenance:	No Charge	Change of Use: \$50.00
Accessory Use/Structure:	\$50.00	Home Occupation: \$25.00

Date: 2/15/2022 **TMS #:** 1470500018

Applicant's Name: John Fitzpatrick

Name of Business Contact: John Fitzpatrick

Address: 2890 Seabrook Island Rd **Phone:** 620-762-3489

City: Seabrook Island **State:** SC **Zip:** 29455

Property Owner's Name: The Club at Seabrook Island

Address: 1002 Landfall Way **Phone:** 843-768-2500

City: Seabrook Island **State:** SC **Zip:** 29455

Property Location Address: 3771 Seabrook Island Rd

Lot: _____ **Block:** _____ **Base Flood Elev.** _____ **Zone:** Commercial

Purpose of Permit: Expansion of back Deck

Value of Construction: \$130,000 **POA Approval:** _____

Applicant's Signature: 

****This is an application only. The permit will be issued upon approval by the Town of Seabrook Island.**



SEABROOK ISLAND
CLUB

To the Town of Seabrook Island Planning Commission.

Our new deck at the club house has been a hit with our members, it has become a very busy congregating spot. We would like to increase the square footage of the deck to allow a larger congregation. All the work is defined in the architectural drawings and details to be consistent with the existing deck and surrounding area meeting all the county building codes. The new work will be \$130,000.

John Fitzpatrick

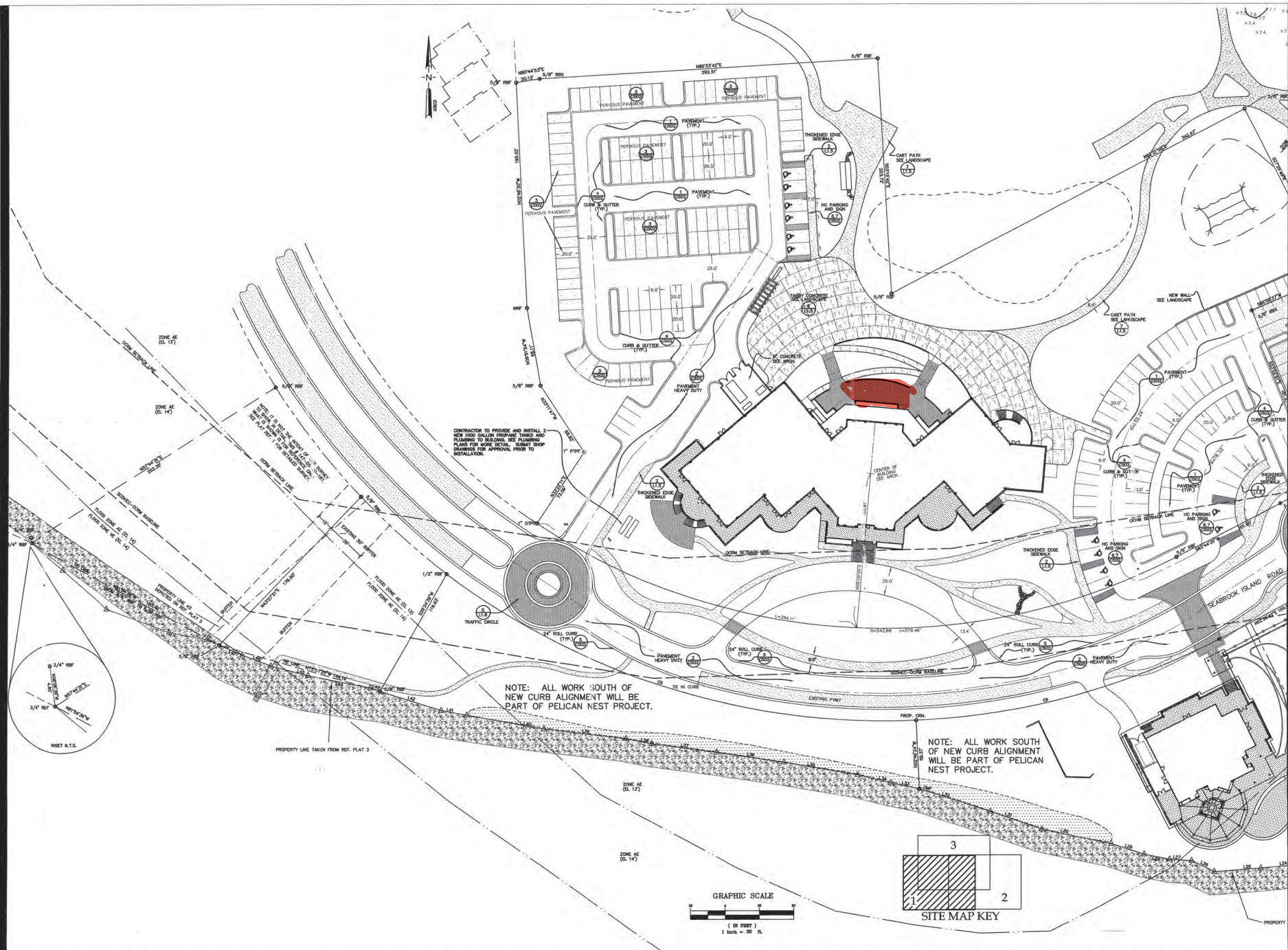

NOTE: FOR ALL HARDSCAPES NOT NOTED OR DETAILED SEE LANDSCAPE ARCHITECTURE PLANS.

NOTE: CONTRACTOR WILL RECEIVE A CADD COPY OF THIS SITE PLAN WITH SURVEY CONTROL FOR USE OF CONTRACTOR'S REGISTERED LAND SURVEYOR TO ASSIST IN LAYOUT.

Job Number	04611	Client	Seabrook Island Association, Inc.
Drawn	ELC	Checked	ELC
Date	12/1/2016		

FORSBERG ENGINEERING AND SURVEYING, INC.
 1000 W. 10TH STREET, SUITE 100, CHARLOTTE, NC 28202
 PHONE: 704.375.1111 FAX: 704.375.1112
 WWW.FORSBERGENGINEERING.COM

STATE OF NORTH CAROLINA
 REGISTERED PROFESSIONAL ENGINEER
 LICENSE NO. 48402
 J. J. FORSBERG

STATE OF NORTH CAROLINA
 REGISTERED PROFESSIONAL LAND SURVEYOR
 LICENSE NO. 40007
 J. J. FORSBERG

THE ISLAND HOUSE
 SEABROOK ISLAND HORIZON PLAN
 SEABROOK ISLAND, SC

Click/Boehm & Associates, Inc. Architecture/Planning/Interior Design

SITE PLAN
 C301

409 King Street Suite 100 Charleston, SC 29403 843/577-6377

DRAWINGS MAY NOT BE REPRODUCED WITHOUT PERMISSION
ALL RIGHTS RESERVED
MEMBER AMERICAN INSTITUTE OF ARCHITECTS
40 HERBULEY STREET, SUITE 15, CHARLOTTE, SOUTH CAROLINA
SMHA, INC.
COPYRIGHT 2018

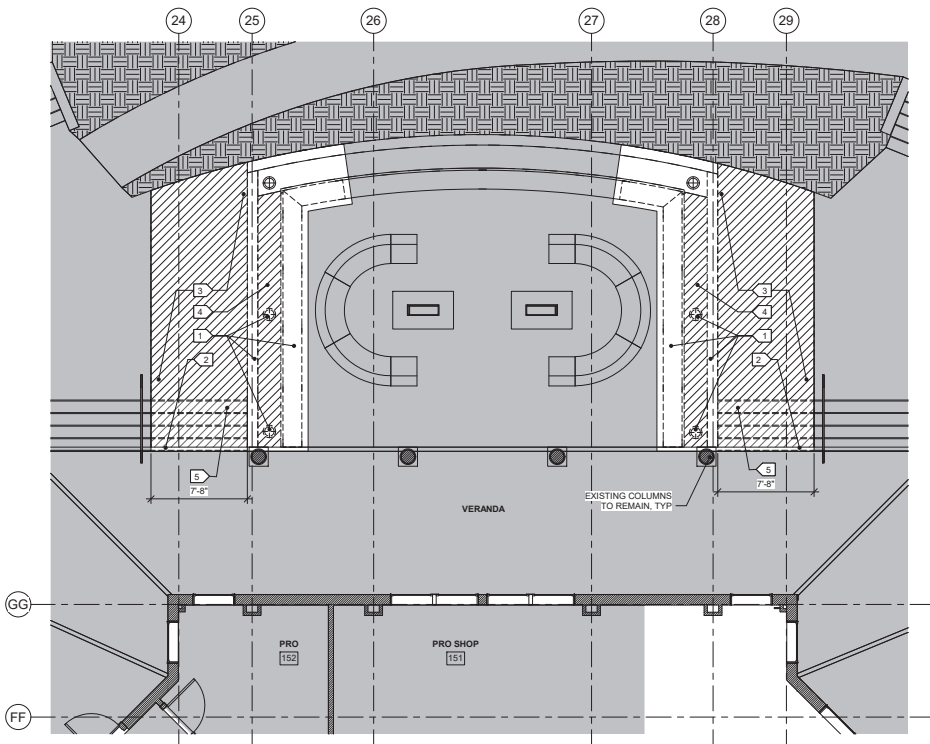

1 FIRST FLOOR DEMO PLAN - VERANDA
1/4" = 1'-0"

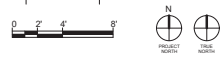

DEMOLITION NOTES:
(APPLY TO THIS SHEET ONLY)

- 1 REMOVE EXISTING SEGMENTAL RETAINING WALL, BENCH AND LANDSCAPE LIGHTING, TO BE RELOCATED IN NEW CONSTRUCTION TO THE EXTENT POSSIBLE
- 2 REMOVE LEADING PERIMETER TRIM BOARD
- 3 DEMOLISH EXISTING CONCRETE
- 4 DEMOLISH EXISTING PLANTER BED.
- 5 PARTIALLY DEMOLISH EXISTING STAIR

DEMOLITION LEGEND:

- EXISTING CONSTRUCTION TO REMAIN
- WALL OR ELEMENTS TO BE REMOVED
- EXTENT OF FLOOR SLAB TO BE REMOVED, COORDINATE DIMENSIONS AND LOCATIONS WITH STRUCTURAL AND UTILITIES
- NOT IN SCOPE
- DEMOLITION TAG

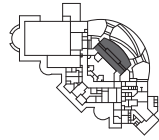

PROJECT INFORMATION

owner
SEABROOK ISLAND CLUB
3771 Seabrook Island Rd.
Johns Island, SC 29455
Caleb Elledge
843.768.2500
celledge@discoverseabrook.com

general contractor
Trident Construction
2245 Technical Parkway
North Charleston, SC 29406
Jay Handegan
843.576.3090
jhandegan@tridentcon.com

architect
SMHa, INC.
400 Hibben St.
Mount Pleasant, SC 29464
Jeff Johnston
843.881.7642
jjohnston@smha.com

electrical
ETI ENGINEERING, LLC
5725 Bush River Rd
Columbia, SC 29212
Troy Lowder
803.233.9396
tlowder@etiservices.net

interior
KENT INTERIOR DESIGN, INC.
2240 Heritage Dr
Atlanta, GA 30345
Karen Kent
404.643.2650
karen.kent@kentinteriordesign.com

DRAWING INDEX

Revision No.	Issue Date	Sheet No.	Sheet Title
01 GENERAL	01.14.22	A000	COVER SHEET & DEMO PLAN
02 ARCHITECTURAL	01.14.22	A001	EXISTING PHOTOS
	01.14.22	A101	FLOOR PLAN - VERANDA & POUR STATION
03 STRUCTURAL	01.14.22	S101	PLANS - FOUNDATION & VERANDA DECK FRAMING
	01.14.22	S201	DETAILS

CONSTRUCTION DOCUMENTS

date of issue: 01.14.22

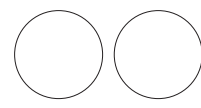

SMHa project no: 2202



SEABROOK ISLAND CLUB
ISLAND HOUSE VERANDA DECK EXPANSION

TMS #1470500018
3771 SEABROOK ISLAND RD, JOHNS ISLAND, SC 29455

project number **2202**

SEABROOK ISLAND CLUB
ISLAND HOUSE VERANDA DECK EXPANSION

TMS #1470500018
 3771 SEABROOK ISLAND RD.
 JOHNS ISLAND, SC 29455

 seal / signature

phase _____ date of issue _____
CONSTRUCTION DOCUMENTS 01.14.22

rev no.	description	revisions	date

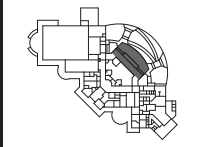

key plan
 sheet title
EXISTING PHOTOS

sheet number
A001

drawn by: Author print date:



1



2

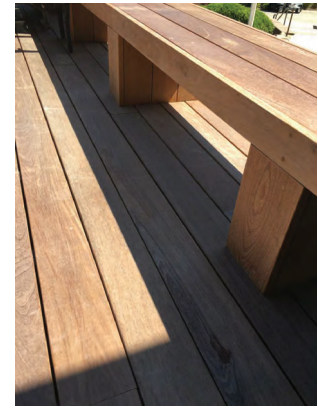

3



4



5



6



7



8



9

G
 F
 E
 D
 C
 B
 A

- LEGEND:**
- EXISTING CONSTRUCTION TO REMAIN
 - NEW CONSTRUCTION
 - NOT IN SCOPE
 - FD FLOOR DRAIN - SEE PLUMBING
 - FS FLOOR SINK - SEE PLUMBING
 - ⊕ E2 EXTERIOR LIGHT FIXTURE - LANDSCAPE

- CONSTRUCTION NOTES**
(APPLY TO THIS SHEET ONLY)
- 1 VERSA-LOK "ACCENT" WITH CAP UNIT TOP - MATCH T.O. WALL ELEVATION TO EXISTING T.O. SEGMENTAL RETAINING WALL ELEVATION - APPROX 15.55. MATCH NEW WALL CONSTRUCTION AND MATERIALS TO EXISTING SEGMENTAL RETAINING WALL.
 - 2 MATCH ELEVATION OF PLANTER TO EXISTING PLANTER ELEVATION - APPROX 15.45
 - 3 INTENT IS FOR ALL FINISH TRIM TO BE GAPPED FROM BLOCKING WITH SPACERS TO ALLOW DRAINAGE BEHIND TRIM
 - 4 NEW PORCH EXTENSION - MATCH FINISHES TO EXISTING PORCH. ALIGN FFE WITH EXISTING ADJACENT VERANDA FFE.
 - 5 WAC LANDSCAPE LIGHTING (CANOPY LED AREA LIGHT 6051) TO BE INSTALLED. TIE INTO EXISTING LANDSCAPE LIGHTING.
 - 6 WAC LANDSCAPE LIGHTING (CANOPY LED AREA LIGHT 6051) TO BE INSTALLED. TIE INTO EXISTING LANDSCAPE LIGHTING.

project number **2202**

SEABROOK ISLAND CLUB

ISLAND HOUSE VERANDA DECK EXPANSION

TMS #1470500018
3771 SEABROOK ISLAND RD.
JOHNS ISLAND, SC 29455

seal/signature

phase _____ date of issue _____

CONSTRUCTION DOCUMENTS 01.14.22

revision	description	date

key plan

FLOOR PLAN - VERANDA & POUR STATION

sheet number **A101**

drawn by: _____ Author _____ print date: _____

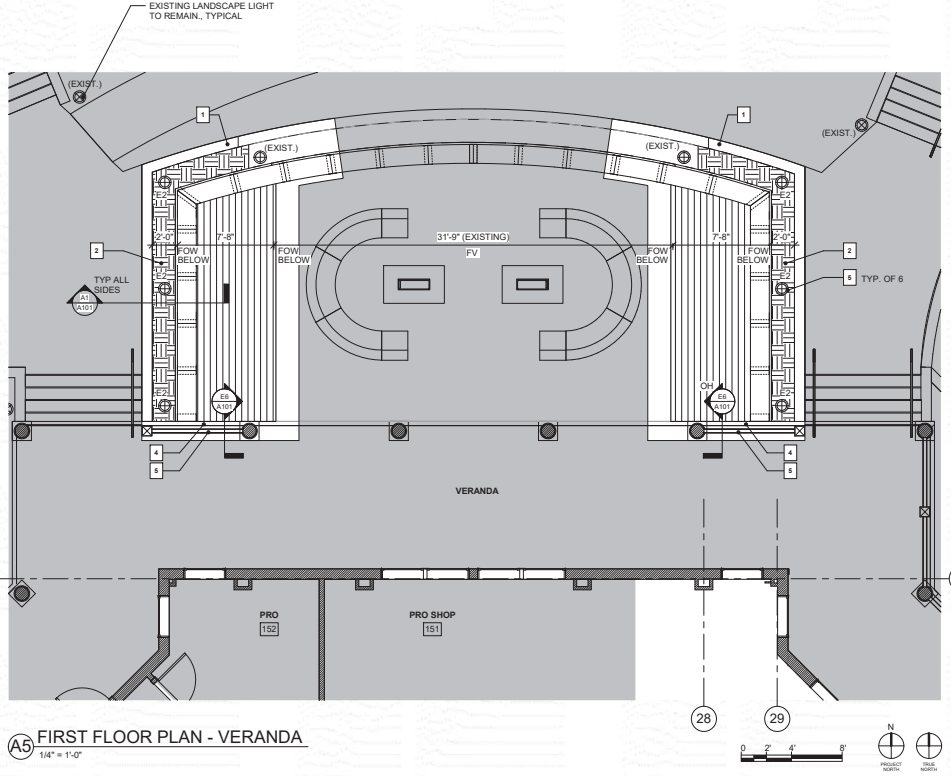
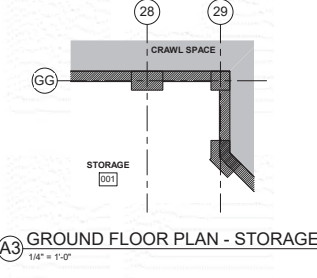
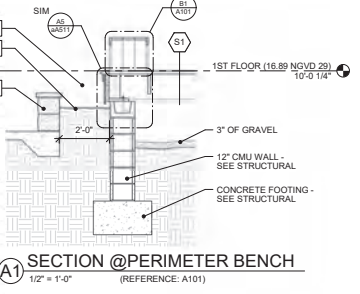
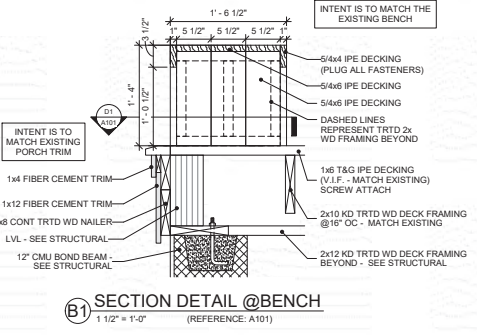
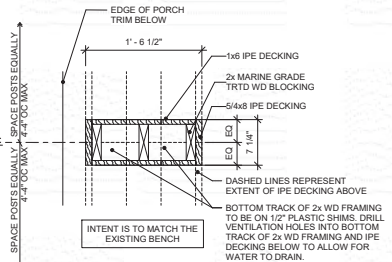
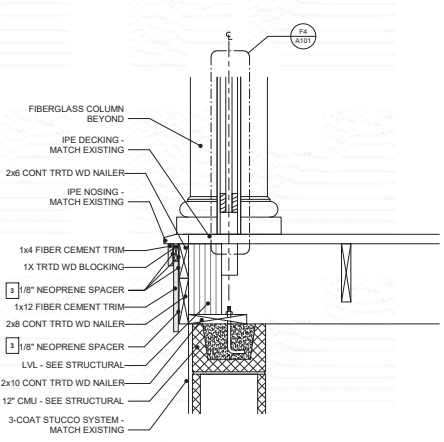
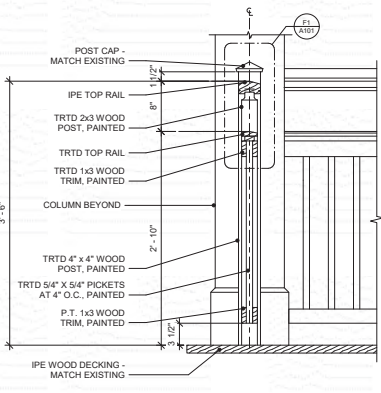
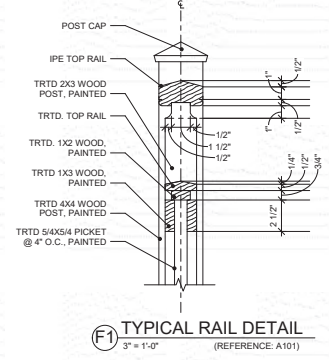

Scale: 0 2 4 8'

North Arrow

DRAWING SHALL NOT BE REPRODUCED WITHOUT PERMISSION
 ALL RIGHTS RESERVED
 MEMBER ARCHITECTURE OF PROTECTA
 301 HENRI STREET, MOUNTAIN VIEW, SOUTH CAROLINA
 29645
 803.767.7238
 COPYRIGHT 2022

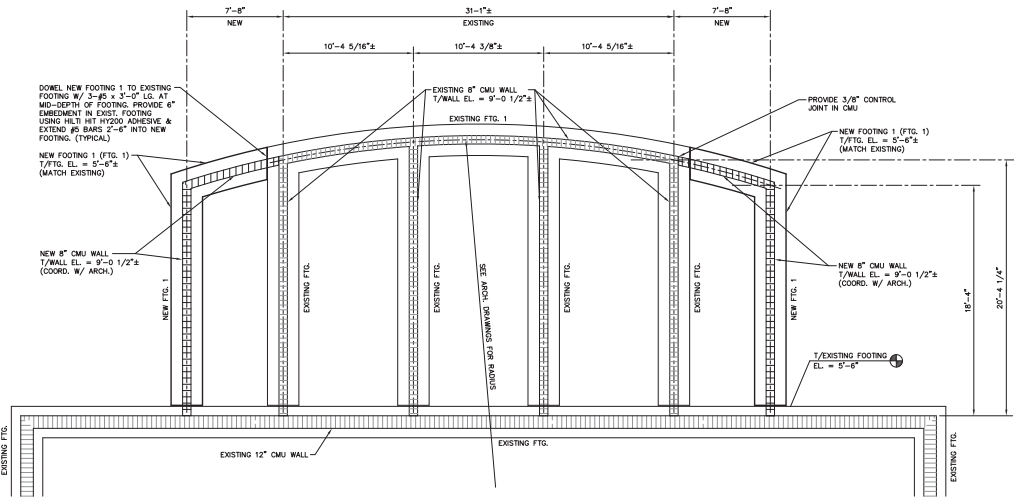

FOUNDATION PLAN – FOR NEW VERANDA
1/4"=1'-0"

NOTE:
COORDINATE ALL DIMENSIONS WITH ARCHITECTURAL DRAWINGS.

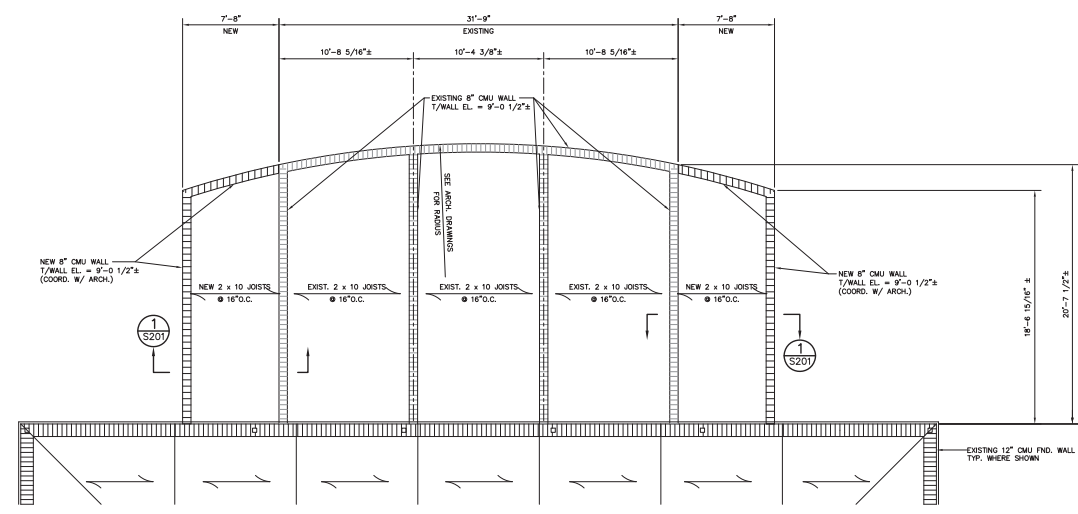

FRAMING PLAN – FOR NEW VERANDA
1/4"=1'-0"

NOTE:
COORDINATE ALL DIMENSIONS WITH ARCHITECTURAL DRAWINGS.



GENERAL NOTES

- DESIGN CRITERIA: 2018 IBC/ASCE 7-16 RISK CATEGORY II
FLOOR LIVE LOAD: 100 PSF, PORCHES
WIND LOAD: N/A
SEISMIC LOAD: N/A
FOUNDATIONS: BASED ON ORIGINAL GEOTECHNICAL REPORT BY SAME
- CARE SHALL BE TAKEN WITH DEMOLITION OF ORIGINAL CONSTRUCTION SO AS NOT TO DAMAGE EXISTING CONSTRUCTION TO REMAIN. GENERAL CONTRACTOR IS RESPONSIBLE FOR SHORING EXISTING CONSTRUCTION PRIOR TO DEMOLITION. INSPECT CONDITIONS OF EXISTING CONSTRUCTION AND CONFIRM FOOTING CONFIGURATIONS. REPORT ANY DETERIORATED CONDITIONS TO THE ARCHITECT.
- PRIOR TO CASTING NEW CONCRETE FOOTINGS, THOROUGHLY COMPACT SUBGRADE.
- NEW FOOTINGS MUST BE SIDE FORMED. NO EARTH FORMS ARE ALLOWED.
- NEW FOOTINGS SHALL BE DOWELED INTO EXISTING WHERE SHOWN USING #4 @ 12" ON CENTER. PROVIDE 3" INCH REINFORCED SURFACES ON EXISTING FOOTINGS TO ACT AS KEYS.
- ALL NEW CONCRETE FOOTINGS SHALL HAVE A MINIMUM 28-DAY COMPRESSIVE STRENGTH OF 3000 PSI. ALL CONCRETE WORK SHALL COMPLY WITH ACI 301 AND 318.
- REINFORCING SHALL COMPLY WITH ASTM A615, GRADE 60. MINIMUM SPUCE LENGTHS FOR NO. 5 BARS 2'-0".
- NEW CONCRETE MASONRY SHALL COMPLY WITH ACI 530. BLOCK SHALL CONFORM TO ASTM C90. LIGHTWEIGHT TYPE. MORTAR SHALL BE TYPE S AND BE A PRE-MIXED BLEND OF PORTLAND CEMENT AND LIME, OR MORTAR CEMENT. MASONRY CEMENT IS NOT ALLOWED. GROUT SHALL HAVE A MINIMUM 28-DAY COMPRESSIVE STRENGTH OF 3000 PSI AND SHALL HAVE A SLUMP OF BETWEEN 4 TO 5 INCHES.
- ALL WOOD FRAMING SHALL BE PRESSURE TREATED. ANCHORS FOR CONNECTING WOOD TO MASONRY SHALL BE HOT-DIPPED GALVANIZED. NEW JOIST HANGERS ATTACHED TO TREATED WOOD SHALL BE HOT-DIPPED GALVANIZED USING HOT-DIPPED GALVANIZED SCREWS AND WALL.
- NEW WOOD FRAMING SHALL BE SYP NO. 1 OR BETTER.

project number **2202**

SEABROOK ISLAND CLUB
ISLAND HOUSE VERANDA DECK EXPANSION

TMS #1470500018
3771 SEABROOK ISLAND RD.
JOHNS ISLAND, SC 29455



CONSTRUCTION DOCUMENTS 01.14.22

rev no. description revision date

key plan cover title
PLANS - FOUNDATION & VERANDA DECK FRAMING

sheet number
S101

drawn by: JKG pdt: ddb

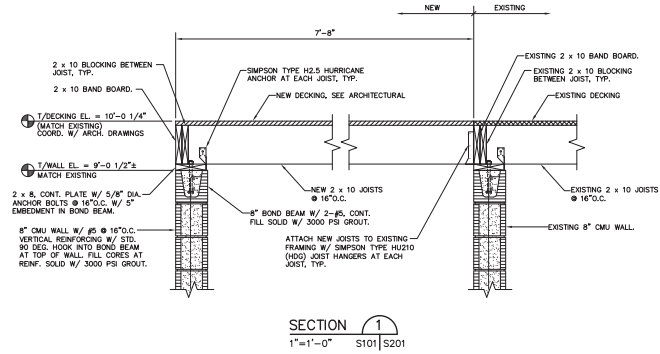
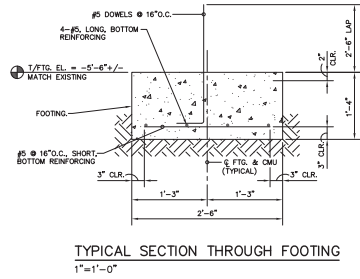

project number **2202**

SEABROOK ISLAND CLUB
ISLAND HOUSE VERANDA DECK EXPANSION

TMS #1470500018
3771 SEABROOK ISLAND RD.
JOHNS ISLAND, SC 29455



CONSTRUCTION DOCUMENTS 01.14.22

rev. no.	description	revisors	date

key plan sheet title
DETAILS

sheet number
S201

drawn by: JKO gph date:



MEMORANDUM

TO: Planning Commission Members
FROM: Tyler Newman, Zoning Administrator
SUBJECT: Commercial Plan Review: Bohicket Marina Day Docks
MEETING DATE: March 9, 2022

The Planning Commission is asked to review and approve a request from Bohicket Creek Investors LLC to install three sections of floating docks at Bohicket Marina. The floating docks will be located in Bohicket Creek, adjacent to 1880 Andell Bluff Boulevard.

The applicant's plans, which have been approved and permitted by SCDHEC-OCRM, contemplate the installation of three sections of floating docks, approximately 522 linear feet in total between the forklift pier and C dock at Bohicket Marina. The proposed floating docks will be connected to the forklift pier with an ADA ramp access which will increase access to the docks.

The property is part of the Bohicket Marina Village Planned District (PD) and is properly zoned for a marina and associated structures.

Copies of the applicant's narrative, proposed dock layout, site overview, and OCRM approval are included for review.

Staff Recommendation

The proposed floating docks were reviewed by town staff and found to comply with all requirements of the Development Standards Ordinance. Therefore, staff recommends in favor of **APPROVAL** of the request, subject to the Planning Commission's review and approval of proposed materials and colors.

While Article 14 of the Development Standards Ordinance requires Planning Commission review of both a Preliminary and Final Site Plan, given the limited scope of this project, as well as its conforming status, staff recommends approving the drawing as submitted and waiving the requirement for an additional Final Site Plan Review.

Respectfully submitted,

Tyler Newman
Zoning Administrator

TOWN OF SEABROOK ISLAND

**2001 Seabrook Island Road
Seabrook Island, SC 29455
843-768-9121**

ZONING PERMIT APPLICATION

New Construction:	\$200.00 (SF) / \$350.00 (MF/Commercial)		
Addition:	\$150.00 (SF) / \$250.00 (MF/Commercial)		
Major Renovation (>50% FMV):	\$200.00 (SF) / \$250.00-\$350.00 (MF/Commercial)		
Minor Renovation (≤50% FMV):	\$25.00 (SF) / \$25.00-\$150.00 (MF/Commercial)		
Minor Repairs & Maintenance:	No Charge	Change of Use:	\$50.00
Accessory Use/Structure:	\$50.00	Home Occupation:	\$25.00

Date: 2/25/22 **TMS #:** Text

Applicant's Name: Bohicket Creek Investors LLC

Name of Business Contact: Mike Shuler

Address: 1880 Andell Bluff Blvd **Phone:** 8434254104

City: Seabrook Island **State:** SC **Zip:** 29455

Property Owner's Name: Bohicket Creek Investors LLC

Address: 1880 Andell Bluff Blvd **Phone:** 843.425.4104

City: Charleston **State:** SC **Zip:** 29455

Property Location Address: Same as above

Lot: _____ **Block:** _____ **Base Flood Elev.** 9 **Zone:** AE

Purpose of Permit: Install new docks

All necessary OCRM and Army Corps of Engineers Permits in hand

Value of Construction: _____ **POA Approval:** _____

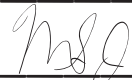
Applicant's Signature: 

****This is an application only. The permit will be issued upon approval by the Town of Seabrook Island.**



TOWN OF SEABROOK ISLAND
 2001 Seabrook Island Road
 Seabrook Island, SC 29455
 843-768-9121

ZONING PERMIT

Permit # _____ Business License # _____

Date: 2/25/22 Fee: _____ Cash () Check # _____

Applicant's Name: Bohicket Creek Investors LLC

Name of Business Contact: Mike Shuler

Address: 1880 Andell Bluff Blvd Phone: 843.425.4104

City: Seabrook Island State: SC Zip: 29455

Property Owner's Name: Bohicket Creek Investors LLC

Address: 1880 Andell Bluff Blvd Phone: 843.425.4104

City: Seabrook Island State: SC Zip: 29455

Property Location Address: 1880 Andell Bluff Blvd / Bohicket Marina

Lot: _____ Block: _____ Base Flood Elev: 9 Zone: AE

TMS #: 2040000321

Purpose of Permit: Install new docks

All necessary OCRM and Army Corps of Engineers Permits are in hand.

Value of Construction: _____ POA Approval _____ (date)

Applicant's Signature: [Signature] (date)

Zoning Administrator's Signature: _____ (date)

The applicant is responsible for obtaining a permit and necessary inspections from Charleston County.

This Zoning Permit is valid for six (6) months. The action for which this permit was obtained must be taken within that time period. If this Zoning Permit is for issuance of a Building Permit, such Building Permit is valid for a period of one (1) year as described in the Town Code. Any extensions, alterations, or amendments must be must approved by the Town.

Permit Fee: \$ _____

Business License Update: _____

Total: \$ _____



February 25, 2022

RE: Addendum to Zoning Permit form

Dear Mr. Newman and members of the Town of Seabrook Planning Commission:

Thank you for your consideration of the enclosed submittal for “Zoning Permit” for the installation of “Day Docks” at Bohicket Marina.

Our fully engineered and permitted plans with OCRM/Army Corps contemplate installation of 3 sections of floating docks, approximately 522 linear feet in total between the forklift pier and C dock. These floating docks will be connected to the new forklift pier that is currently under reconstruction with an ADA ramp access which will make ramp access to the docks substantially more accessible for ALL people.

Installation of these “day docks” has been planned for many years, predating the new ownership. The new ownership feels this is a very important addition to the marina for several reasons including:

- A) Provision of ADA access to the main waterfront area of the Marina, much closer than the far reaches of the marina, improves access for ALL
- B) Will encourage public access by water as “day dockage” to patronize restaurants and retail shops
- C) Will reduce non-marina boaters from “stealing” privately owned slips while patronizing restaurants and retail, which is an ongoing problem that is very difficult to police
- D) Will allow for additional slippage for staging of vessels, which will be helpful in preventing displacement of vessels during Marina renovation projects, fishing tournaments, general marina operations, etc.

Installation of these day docks will be staged in a way that will have minimal impact on current marina operations, and will be much less impactful to install while other marina improvements remain ongoing. This project is incurring a substantial expense which the ownership of Bohicket is bearing fully and independently of the regime and private slip owners.

Thank you for your consideration, and we look forward to continued partnership with Seabrook and its residents to make Bohicket a world-class marina.

Sincerely,

Mike Shuler

Principal

Bohicket Creek Investors, LLC

ALL DOCKS TO BE BUILT USING HEAVY DUTY CONSTRUCTION WITH 20"±1" FREEBOARD

- NOTES:
1. HEAVY DUTY FRAMING .60 CCA TREATMENT
 2. UTILITY CUT OUTS
 3. SPLICED CONNECTION MAINS RIGID CONNECTION TO EXISTING
 4. 16" DEEP FLOATS WITH NOMINAL 0.150" WALL THICKNESS
 5. 1"x6" NOMINAL IPE DECKING #10x2½" STAINLESS STEEL DECK SCREWS
 6. 4 PLANK UTILITY PANELS LOCATED EVERY 10'-12'
 7. 12" GALVANIZED IRON CLEATS
 8. 5008 BUMPER (BLACK) SCREW FASTENED WITH #12x1" STAINLESS STEEL TRUSS SCREWS 6" ON CENTER
 10. 12"-14" TIMBER PILES (BY OTHERS) EXTERNAL 23" 4 ROLLER TYPE PILE GUIDES WITH STAINLESS STEEL AXLES
 11. BOHICKET CREEK

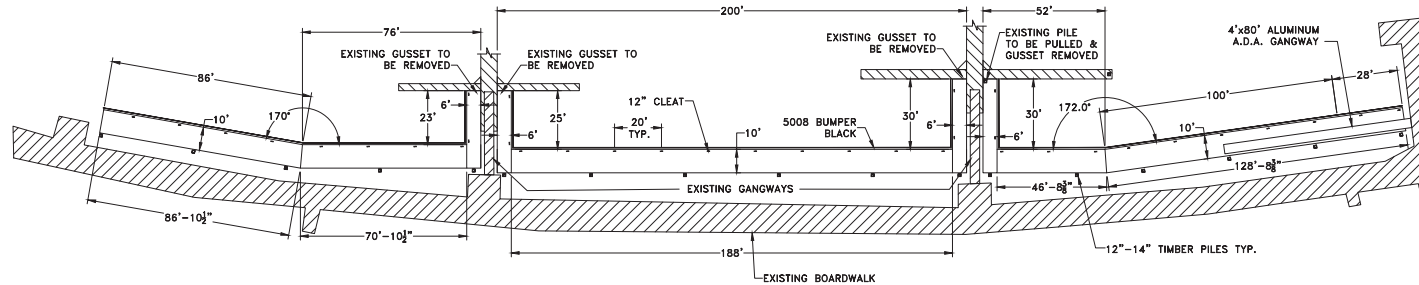

MSD

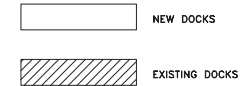

PILE QUANTITIES AND LOCATIONS ARE ESTIMATES ONLY AND HAVE NOT BEEN REVIEWED BY AN ENGINEER.

APPROVED FOR CONSTRUCTION: _____ DATE: _____
By signing and dating this document I authorize Meeco Sullivan to begin engineering, material procurement and fabrication of all contract elements identified hereon. Any subsequent changes may result in additional fees.



P.O. BOX 639
3 CHANCELLOR LANE
WARWICK, N.Y. 10990
PHONE: (845) 986-7377
FAX: (845) 986-8531
EMAIL: DOCKS@MEECOSULLIVAN.COM
WEBSITE: WWW.MEECOSULLIVAN.COM

PROJECT:
BOHICKET CREEK
CHARLESTON, SC

DRAWING TITLE:
CONNECTOR DOCKS
APPROVAL LAYOUT
(PHASE 1)

GENERAL NOTES:

NO.	REVISION	BY	DATE

SCALE: 1"=25'
DATE: 2.2.22
DRAWN BY: G.D.K.
APPROVED BY:
PROJECT #:
SHEET #
SD1

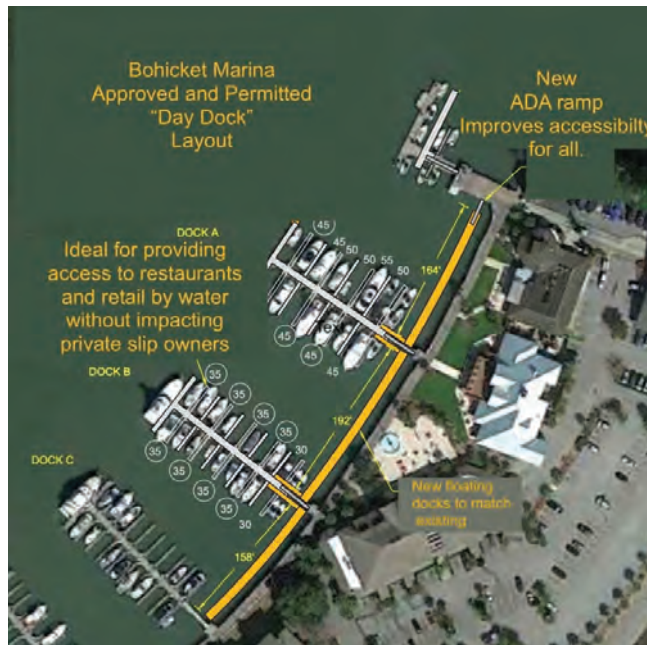



June 27, 2019

Bohicket Investors LLC
1880 Andell Island
Johns Island, SC29455

Re: 1982-07661(18)

Dear Bohicket Investors LLC:

The Office of Ocean and Coastal Resource Management (the Department) has reviewed your application to make modifications to an existing marina at 1880 Andell Bluff Blvd, Johns Island, Charleston County, South Carolina and has issued a permit for this work. You should carefully read the description of the authorized project and special conditions that have been placed on the permit, as these conditions may modify the permitted activity. In addition, there are a series of general conditions that should be reviewed. The original and one photocopy of the permit, as issued, are enclosed. After carefully reading the permit, if you wish to accept the permit as issued, sign and date in the signature block entitled "PERMITTEE" on the original version of the permit **and return it to this Department. Keep the photocopy for your records.**

PLEASE READ CAREFULLY: You are required to sign and return the original version of your permit to this Department. If this permit is not signed and returned within thirty (30) days of issuance, OR appealed within 15 days as described on the enclosed "Guide to Board Review", the Department reserves the right to cancel this permit. Please carefully review the enclosed "Guide to Board Review" for information and deadlines for appealing this permit.

We have also enclosed a "request for a construction placard" card. You must send in this card before the time you wish to start construction. At that time a construction placard will be sent to you to post at the construction site.

PLEASE NOTE: You are not authorized to commence work under the permit until we have received the original version of the entire permit signed and accepted by you, and a construction placard has been issued and posted at the construction site. The receipt of this permit does not relieve you of the responsibility of acquiring any other federal or local permits that may be required. Please return the signed permit to the following address:

Office of Ocean and Coastal Resource Management
1362 McMillan Ave, Suite 400
Charleston, SC29405

Sincerely,

Joshua D Hoke
Project Manager
Critical Area Permitting Section

Enclosure

cc: Mr. Blair Williams, Critical Area Permitting Section Manager

**SOUTH CAROLINA DEPARTMENT OF HEALTH AND ENVIRONMENTAL CONTROL
OFFICE OF OCEAN AND COASTAL RESOURCE MANAGEMENT**

CRITICAL AREA PERMIT & WATER QUALITY CERTIFICATION

Permittee(s): Bohicket Investors LLC

Permit Number(s): 1982-07661(18)

Date of Issuance: June 27, 2019

Expiration Date: June 27, 2024

Location: On and adjacent to Bohicket Creek at 1880 Andell Bluff Blvd, Johns Island
Charleston County, South Carolina (TMS#:2040000295)

SPECIAL
CONDITION(S)

This permit/certification is issued under the provisions of 25A S.C. Code Ann. Regs. 61-101 (Supp. 2005), *et seq.*, and 23A S.C. Code Ann. Regs. 30-1 through 30-18 (Supp. 2005). Additionally, as required by R.61-101, Department staff have reviewed plans for this project and determined there is a reasonable assurance the project will be conducted in a manner consistent with Certification requirements of Section 401 of the Clean Water Act. We also certify that this project, subject to the indicated conditions, is consistent with applicable provisions of Section 303 of the Clean Water Act, as amended, that there are no applicable effluent limitations under Sections 301(b) and 302, and that there are no applicable standards under Sections 306 and 307.

This permit contains required certification pursuant to Section 401 of the Clean Water Act. PLEASE CAREFULLY READ THE ENCLOSED "GUIDE TO BOARD REVIEW."

Please carefully read the project description and any special conditions that may appear on this permit/certification as they will affect the work that is allowed and may modify the work from that shown on the submitted plans. All special conditions attached to the permit will take precedent over submitted plans. If there are no special conditions, then the work is authorized as described in the project description and as modified by general conditions. The general conditions are also a part of this permit/certification and should be read in their entirety. The S. C. Contractor's Licensing Act of 1999, enacted as Section 40-11-5 through 430, requires that all construction with a total cost of \$5,000 or more be performed by a licensed contractor with a valid contractor's license for marine class construction, except for construction performed by a private landowner for strictly private purposes. Your signature on and acceptance of this permit denotes your understanding of the stated law regarding use of licensed contractors. **All listed special and general conditions will remain in effect for the life of the project if work commences during the life of the permit. This applies to permittee, future property owners, or permit assignees.**

DESCRIPTION OF THE PROJECT, AS AUTHORIZED

The work consists of reconfiguring an existing commercial marina to provide for additional floating dock space for transient boaters. In detail, the permittee will remove 6 finger docks on Dock A, remove 8 finger docks on Dock B, remove 4 finger docks on Dock E, remove 1 finger dock on Dock H, remove 1 finger dock on Dock I, install a 10' x 100' floating dock extension floodside of the "T" head of Dock A, install 1,530' of 10' wide floating docks and associated anchor pilings immediately adjacent and parallel to the existing timber boardwalk and bulkhead, and construct a new gangway from the aforementioned floating dock to the fuel dock.

SEE SPECIAL
CONDITION(3)

CRITICAL AREA PERMIT SPECIAL CONDITIONS

1. The operations of the marina shall be reviewed by the Department as deemed appropriate, but at least every five years. Based on this review, the Department may require, among other things, changes or additions to the Operations and Maintenance Manual (manual) to address any water quality or other environmental problems, and a reduction in the size of, or a change in the configuration of, the marina. Such action may be taken at any time the Department determines that significant state water quality compliance or other problems exist, at the time the Department enlarges the closure area, or at the time of a review. The manual submitted for this facility is made a part of this permit and must be followed in the operation of this facility unless otherwise amended in writing by OCRM. The manual must be reviewed and revised to keep it up-to-date with existing facilities and operations. The manual must be in accordance with R. 30-12(E)(6) or the Rules and Regulations for Permitting in the Critical Areas of the Coastal Zone and with OCRM's Marina/Commercial Dock Operations And Maintenance Manual Requirements.
2. An experienced operator shall be in charge of the marina and be responsible for compliance with the issued Operations and Maintenance Manual and with all conditions of the permit.
3. Any painting, major engine repair, or other maintenance which may result in a discharge to the water must be performed in a designated upland site and not in or over the waters of the marina.
4. The storage or disposal of new or used batteries, oil or lubrication containers, fuel containers, solvents, toxic cleaners, paint cans, etc., on the marina docks is prohibited.
5. If power washing of boats is to be conducted at the marina then it must be conducted on a designated upland area and is not allowed over the water. Wastewater from this operation must be properly treated and can not be directly discharged into the adjacent waters.
6. An as-built survey of the dock must be submitted to the Department within 90 days from completion of construction. The survey must be performed by a registered land surveyor, must show all components of the dock, and must list the starting and ending coordinates of the dock walkway in the SC State Plane Coordinate System, which can be obtained by survey-grade Global Positioning System equipment.
7. In the event that any historic or cultural resources and/or archaeological materials are found during the course of work, the applicant must notify the State Historic Preservation Office and the South Carolina Institute of Archaeology and Anthropology. Historic or cultural resources consist of those sites listed in the National Register of Historic Places and those sites that are eligible for the National Register. Archaeological materials consist of any items, fifty years old or older, which were made or used by man. These items include, but are not limited to, stone projectile points (arrowheads), ceramic sherds, bricks, worked wood, bone and stone, metal and glass objects, and human skeletal materials.

WATER QUALITY SPECIAL CONDITIONS

1. The applicant must implement best management practices that will minimize erosion and migration of sediments on and off the project site during and after construction. These practices should include the use of appropriate grading and sloping techniques, mulches, hay bales, silt fences, or other devices capable of preventing erosion, migration of sediments, and

bank failure, all disturbed land surfaces and sloped areas affected by the project must be stabilized.

2. The floating docks must be constructed with encased or encapsulated floatation devices.
3. All efforts must be made to protect existing native riparian vegetation in and along shoreline areas.
4. Litter receptacles must be located near all docks and walkways.
5. All necessary measures must be taken to prevent oil, tar, trash, debris, and other pollutants from entering the adjacent waters or wetlands.
6. Once the project is initiated, it must be carried to completion in an expeditious manner in order to minimize the period of disturbance to the environment.

PERMITTEE'S ATTENTION IS DIRECTED TO GENERAL CONDITIONS NUMBERS FOUR (4) AND (5), BY ACCEPTANCE OF THIS PERMIT, PERMITTEE IS PLACED ON NOTICE THAT THE STATE OF SOUTH CAROLINA, BY ISSUING THIS PERMIT, DOES NOT WAIVE ITS RIGHTS TO REQUIRE PAYMENT OF A REASONABLE FEE FOR USE OF STATE LANDS AT A FUTURE DATE IF SO DIRECTED BY STATUTE.

THE PERMITTEE, BY ACCEPTANCE OF THIS PERMIT, AGREES TO ABIDE BY THE TERMS AND CONDITIONS CONTAINED HEREIN AND TO PERFORM THE WORK IN STRICT ACCORDANCE WITH THE PLANS AND SPECIFICATIONS ATTACHED HERETO AND MADE A PART HEREOF. ANY DEVIATION FROM THESE CONDITIONS, TERMS, PLANS AND SPECIFICATIONS SHALL BE GROUNDS FOR REVOCATION, SUSPENSION OR MODIFICATION OF THIS PERMIT AND THE INSTITUTION OF SUCH LEGAL PROCEEDINGS AS THE DEPARTMENT MAY CONSIDER APPROPRIATE.

**SEE SPECIAL
CONDITION(S)**

Permit Number: 1982-07661(18)

Your signature below, as permittee, indicates that you accept and agree to comply with the terms and conditions of this permit.

PERMITTEE(S)
Bohicket Investors LLC

DATE July 16, 2019

This permit becomes effective when the State official, designated to act for the Office of Ocean and Coastal Resource Management, has signed below.

Josh Hoke

CRITICAL AREA PERMITTING PROJECT MANAGER

Joshua D Hoke

Or Other Authorized State Official

6-27-19

DATE

**SEE SPECIAL
CONDITION(S)**

FOR PERMITTING PURPOSES ONLY
"NOT FOR CONSTRUCTION"

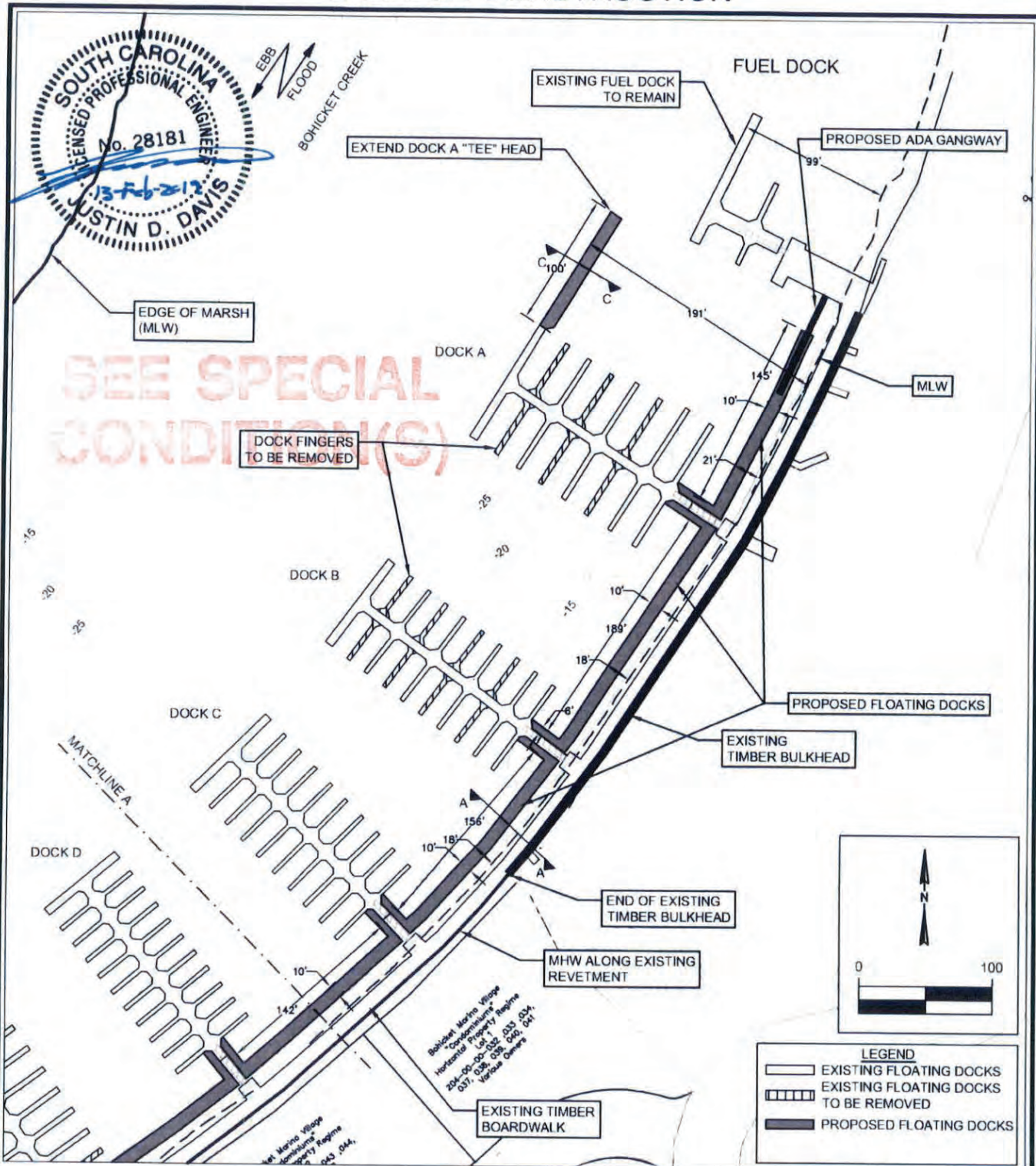

PROJECT: Bohicket Marina Additional Docks
 WATERBODY: Bohicket Creek
 COUNTY: Charleston
 STATE: South Carolina
 LATITUDE: 32° 36' 23" N
 LONGITUDE: 80° 09' 23" W

PROPOSED IMPROVEMENTS
 FUEL DOCK TO DOCK C
 Requested by: Bohicket Investors, LLC
 Project Address: 1880 Andell Bluff Boulevard
 John's Island, SC 29455
 Parcel ID: 2040000295

ATM DESIGN ENGINEERING CONSULTING
 Revised 12-Feb-2019
 SHEET 4

I:\chb\p\c\1\groups\Charleston Shares\Shared Projects\16-2896 Bohicket Modeling & Permitting\3-Permitting Drawings\Revised\Bohicket Permit Drawings-2019-02-12.dwg 4 / 2/12/19

FOR PERMITTING PURPOSES ONLY
"NOT FOR CONSTRUCTION"

**SEE SPECIAL
 CONDITION(S)**

**SECTION A-A: TYPICAL REVETMENT AND PROPOSED
 FLOATING DOCK SECTION - COMMERCIAL AREA**

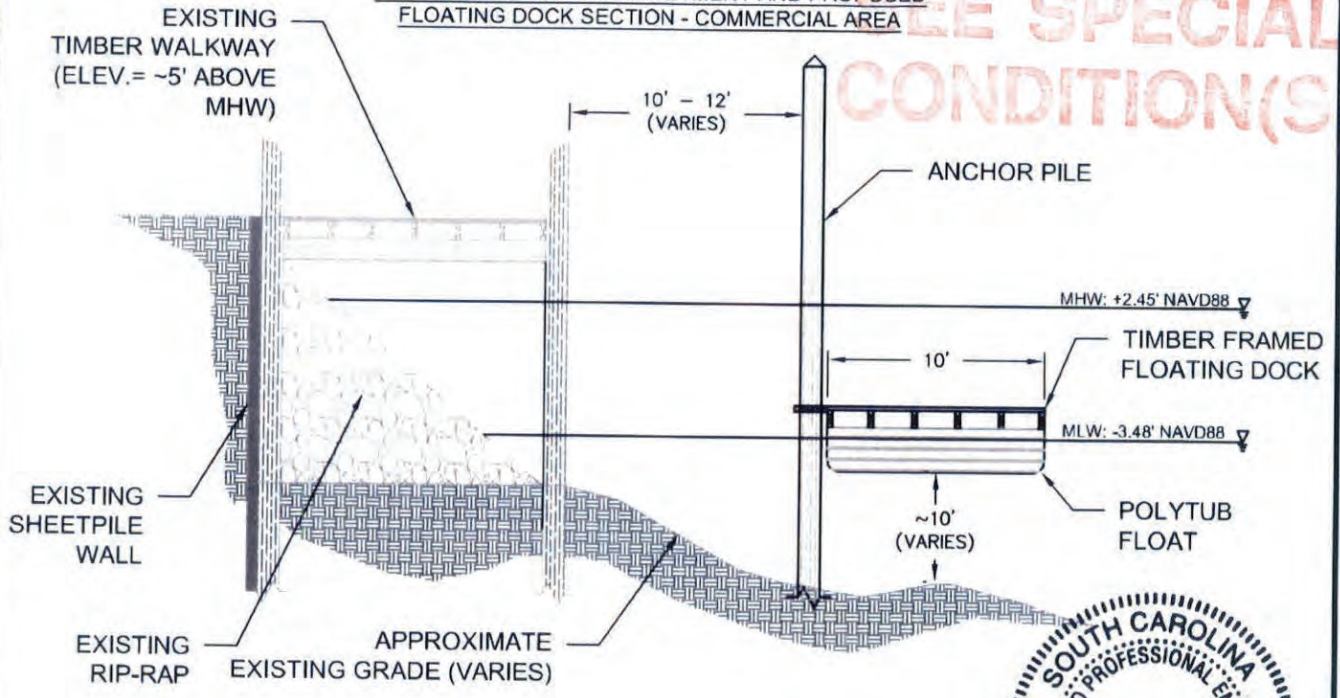

**SECTION B-B: TYPICAL REVETMENT AND PROPOSED
 FLOATING DOCK SECTION - RESIDENTIAL AREA**

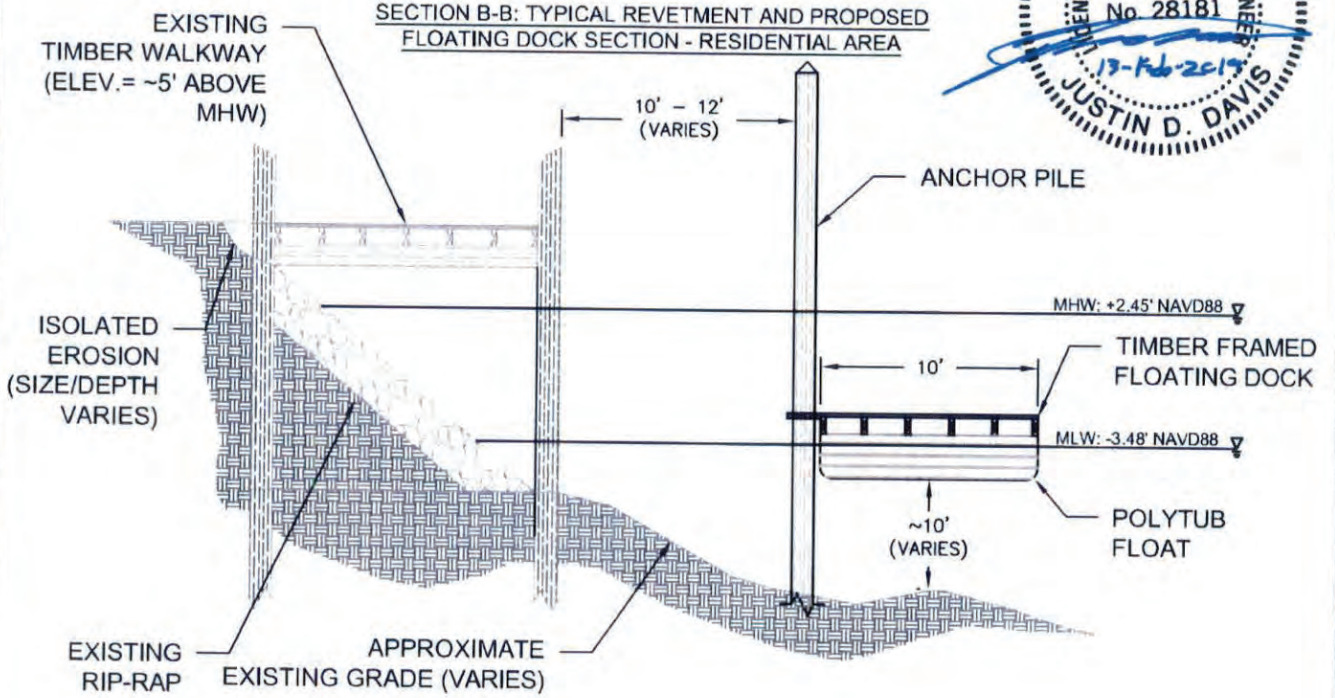

\s\ch\p\c\1\groups\ch\admission\shores\shored\projects\16_2896\bohicket\et\middle\p\3_permitting\Drawings\Review\Bohicket\Permit Drawings-2019 02 12.dwg 7 2/12/19

PROJECT:	Bohicket Marina Additional Docks	PROPOSED IMPROVEMENTS TYPICAL SECTIONS	
WATERBODY:	Bohicket Creek	Requested by: Bohicket Investors, LLC	
COUNTY:	Charleston	Project Address: 1880 Andell Bluff Boulevard John's Island, SC 29455	
STATE:	South Carolina	Parcel ID: 2040000295	Revised 12-Feb-2019 SHEET 7
LATITUDE:	32° 36' 23" N		
LONGITUDE:	80° 09' 23" W		

FOR PERMITTING PURPOSES ONLY
 "NOT FOR CONSTRUCTION"

SEE SPECIAL
 CONDITION(S)

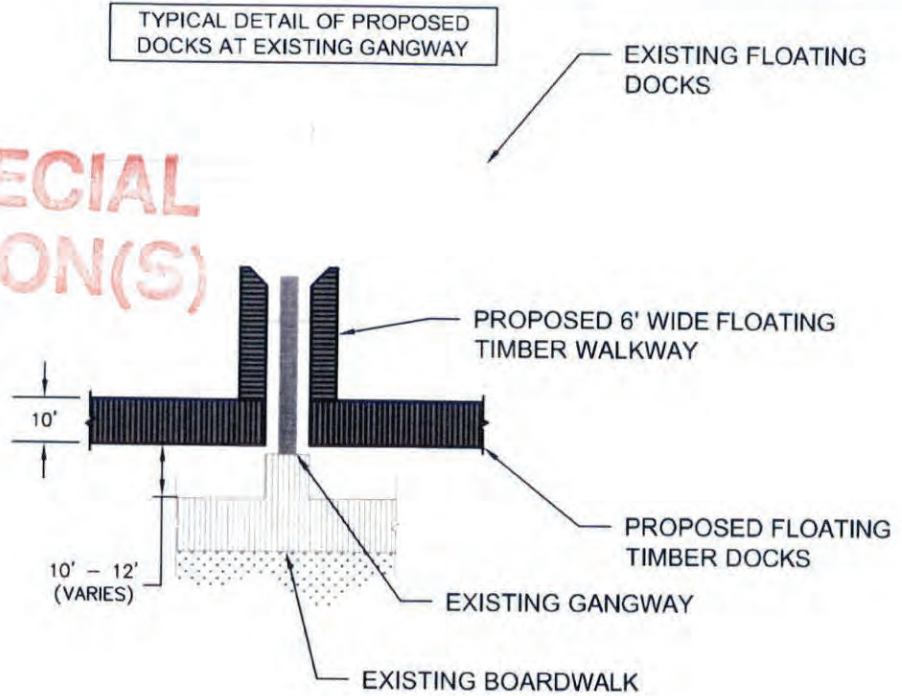

SECTION C-C: TYPICAL FLOATING DOCK A
 EXTENSION SECTION

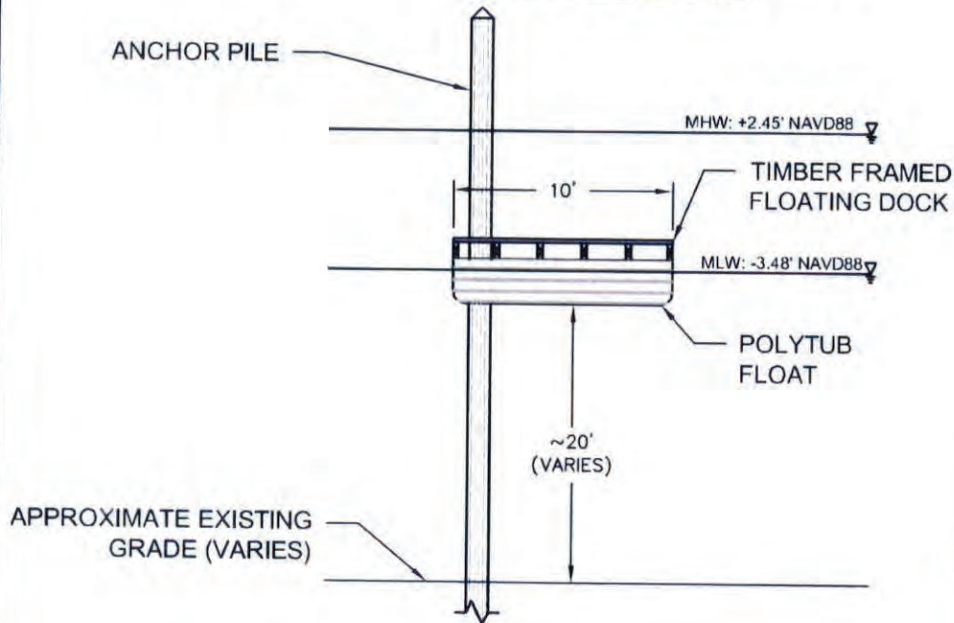

w:\bhp\p\c\higgins\charleston\shores\shared\projects\16-2896 Bohicket Marina Additional Docks\Permitting\Drawings\Revised\Bohicket Marina Additional Docks.dwg # 2/12/19

PROJECT: Bohicket Marina Additional Docks
 WATERBODY: Bohicket Creek
 COUNTY: Charleston
 STATE: South Carolina
 LATITUDE: 32° 36' 23" N
 LONGITUDE: 80° 09' 23" W

PROPOSED IMPROVEMENTS
 TYPICAL DETAILS & SECTIONS
 Requested by: Bohicket Investors, LLC
 Project Address: 1880 Andell Bluff Boulevard
 John's Island, SC 29455
 Parcel ID: 2040000295

Revised 12-Feb-2019
 SHEET 8